

Customer Name:

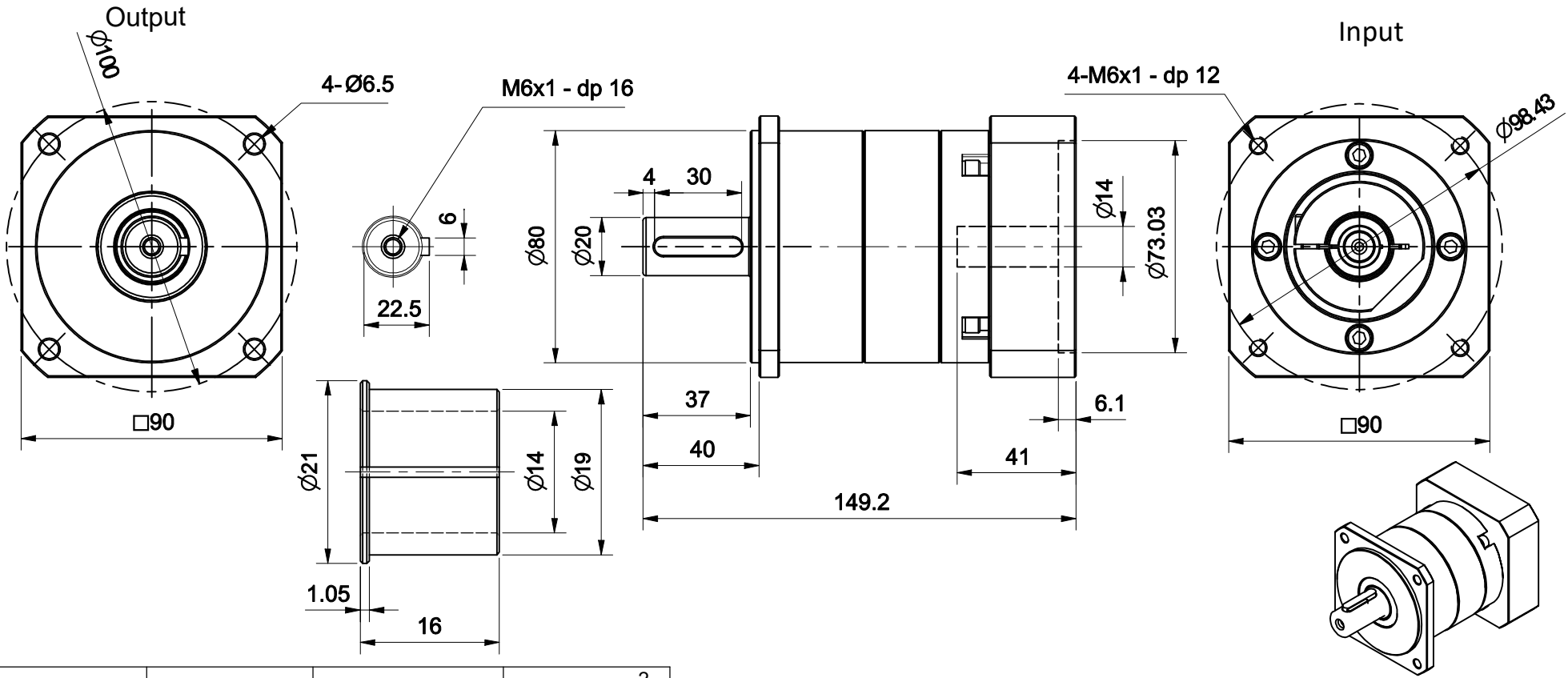

Transmission Ratio	(<u> A </u>):1	Mass Moments Of Inertia	(<u> \ </u>)Kg.cm ²													
Rated Output Torque	(<u> C </u>)Nm	Max Output Torque	(<u> D </u>)Nm		10	0.44	82	246	Sign/Date							
Rated Input Speed	3000rpm	Max Input Speed	5000rpm		7	0.45	116	348								
Max Radial Force	1100N	Max Axial Force	1320N		5	0.47	135	405								
Efficiency	≥ 97%	Operating Temperature	-20°~+90°		4	0.48	116	348								
Mounting Position	Any	Lubrication Method	Synthetic grease		3	0.61	108	324								
Weight ±3%	\	Service Life	20000h	Ratio	A	B	C	D		Ratio	A	B	C	D		
Standard Backlash	≤ 8 arcmin	Protection Class	IP65	Note						Precision Planetary Reducer	GA090					
Motor Power	-- KW	Noise Level	65dB								GA090-L1-R9					
Motor Dimensions											Shaft Type	Precision				

Above specifications are for standard reducer and may be subject to change without notice.