

Customer name:

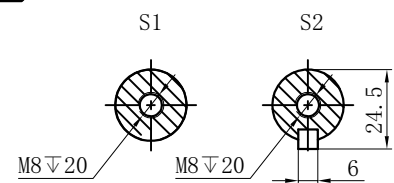
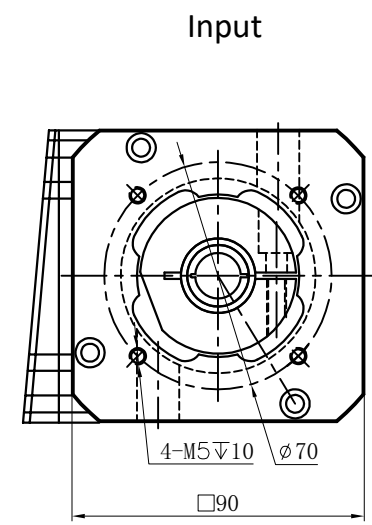
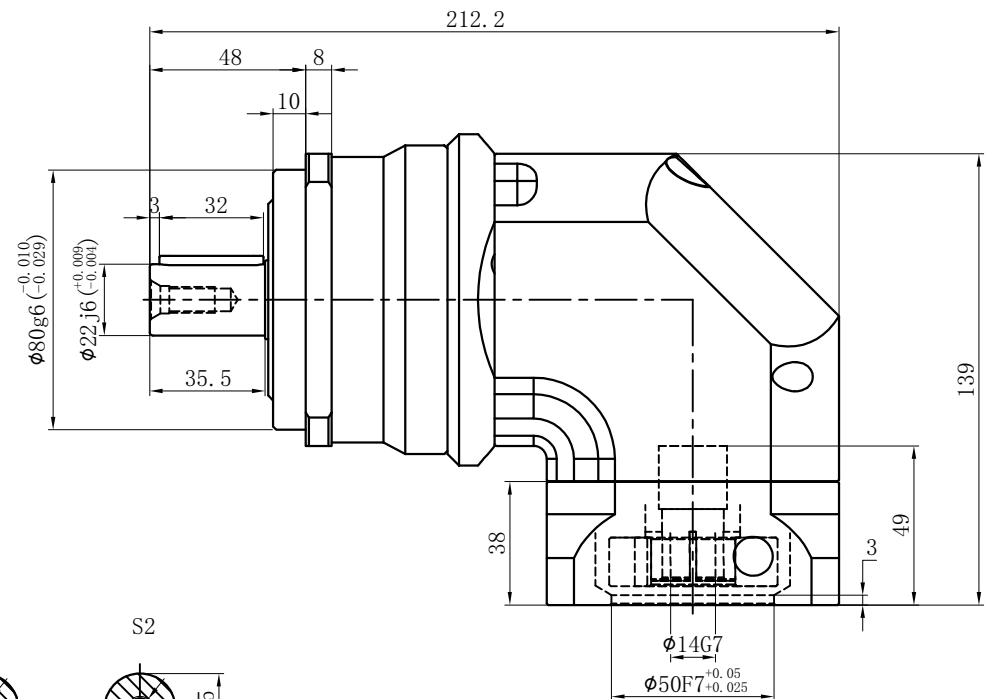
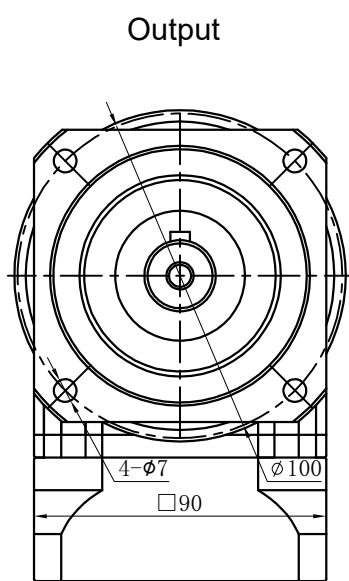

| | | | |
|---------------------|------------|-------------------------|-------------------------|
| Transmission ratio | (A):1 | Mass moments of inertia | (B)Kg.cm ² |
| Rated output torque | (C)Nm | Max.output torque | (D)Nm |
| Rated input speed | 3000rpm | Max input speed | 5000rpm |
| Max.radial force | 3250N | Max.axial force | 1625N |
| Efficiency | ≥ 95% | Operating temperature | -20°~+90° |
| Mounting position | Any | Lubrication method | Synthetic grease |
| Weight ±3% | 6.4Kg | Service life | 20000h |
| Standard backlash | ≤ 6 arcmin | Protection class | IP65 |
| Motor power | | Noise level | 67dB |
| Motor dimensions | | | |

| Ratio | A | B | C | D | Sign/Date | Ratio | A | B | C | D |
|-------|----|------|-----|-----|-----------|-------|------|-----|-----|---|
| | 16 | 1.87 | 115 | 180 | | 20 | 1.87 | 97 | 180 | |
| | 12 | 2.25 | 140 | 180 | | 14 | 1.87 | 135 | 252 | |
| | 10 | 2.25 | 97 | 180 | | 8 | 2.25 | 115 | 216 | |
| | 7 | 2.25 | 135 | 252 | | 6 | 2.25 | 140 | 270 | |
| | 5 | 2.25 | 140 | 270 | | 3 | 2.25 | 85 | 162 | |
| | 4 | 2.25 | 115 | 252 | | | | | | |

| | | | | | | | |
|---------|-----|------|------|--|-----------------------------|----------------------|--|
| Note | | | | | Precision planetary reducer | GCBR090 | |
| φ19-φ14 | | | | | | | |
| Mark | No. | Sign | Date | | GCBR090-L1 | Shaft Type Precision | |
| | | | | | | | |
| | | | | | | | |
| | | | | | | | |